



工程師得見主恩

Seeing Salvation through an Engineer's Eyes

張懋中弟兄

Brother Mau-Chung Frank Chang

Chinese Baptist Church West Los Angeles (CBCWLA)

Sept. 29 2013

永生神的應許

羅馬書 8:28

萬事都互相效力，叫愛神的人得益處。就是按他旨意被召的人。

Romans 8:28

In all things God works for the good of those who love him, who have been called according to his purpose.

我的成長與受浸

- 在中台灣的山間小鎮竹山長大。父親是中學國文教員。幼承庭訓多習孔孟古文精義 (Raised up under orthodox Confucius teaching from a small village in central Taiwan called “Bamboo Mountain”)
- 曾長期接受基礎科學訓練，並專業於高速半導體器件物理，和高頻電子電路及晶片系統之研究 (An engineer who learned fundamental sciences and specializes in semiconductor device physics, circuit & system designs)
- 1979來洛杉磯加大任博士後研究員。由陳聰容弟兄帶入西區華語浸信會。1980與妻麗芳姊妹同時決志，受林牧師浸，歸入主名。其後到千橡鎮洛克威爾科學中心從事高速電子學研究。最後在1997應聘回到洛杉磯加州大學任教。在1998回到西區華語浸信會 (Joined UCLA in 1979 as Postdoc, introduced by Brother T.R. Chen to CBCWLA and baptized together with wife Shelly by Pastor Lin in Oct. 1980, left for industry until 1997 and became a tenured full professor at UCLA and also returned to CBCWLA)

才到美國的新鮮經驗

不一樣的社會，不一樣的人際關係：

- 過馬路車子讓人
- 進門廳有人拉門
- 進電梯有人問層
- 雜貨店員先問好再算帳
- 擋了人家路，人反說 “請原諒我”
- 擠張桌子吃飯，移張空椅子，人問 “我可以嗎？”
- 商店購物，一定時間內，不滿意即退
- 餐館吃飯食物餒了，道歉即換
- 長途電話，撥錯不計費
- 中文博士證書，宣誓即認

老禪遊記裏的君子國？

價值觀(神的道):光明與真理 Value (God's Words): Light & Truth

加州大學



神說:要有光,就有了光.

And God said: "Let there be light."

(創世紀, Genesis 1:3)



你們必曉得真理,
真理必叫你們得以自由.

Then you will know the truth,
and the truth will set you free.

(約翰福音, John 8:32)

加州理工學院

有趣的中美校訓對照 (天道對人德)

Interesting Contrast between Mottos (God versus Man)

加州大學



Let there be light ! 要有光!
Light and Truth ! 光明與真理

耶魯大學



Light and Truth ! 光明與真理

哈佛大學



Veritas (Truth) 真理

加州理工學院



The truth will set you free
真理必叫你們得以自由



敦品勵學
愛國愛人



厚德載物
自強不息



飲水思源
愛國榮校



博學而篤志
切問而近思

得神祝福的美國科技

- 得諾貝爾獎和費爾茲的最多 (More Nobel laureates and Fields medalists)
- 最早實現原子分裂與融合 (First realizing nuclear fusion and fission)
- 登月和機器人登火星 (Landed on Moon and robots landed on Mars)
- 發明
 - Invented
 - AC/DC electricity, telephones, cell phone, television, LCD, LED
 - Airplane,.... developed space shuttle
 - Transistors, ICs, memories, computers, PC, NB, iPad
 - Lasers and fiber optics for telecom
 - Global Positioning System (GPS)
 -
 - 最驚人的發現: 宇宙在大爆炸後產生!!



我為何在這兒？

Why am I here?

宇宙如何開始?

How Did the Universe Get Started?

Astrophysics Drivers for THz Sensors

THz is the primary freq. for line and continuum radiation from cool (5-100 K) gas (atoms and molecules) and dust.

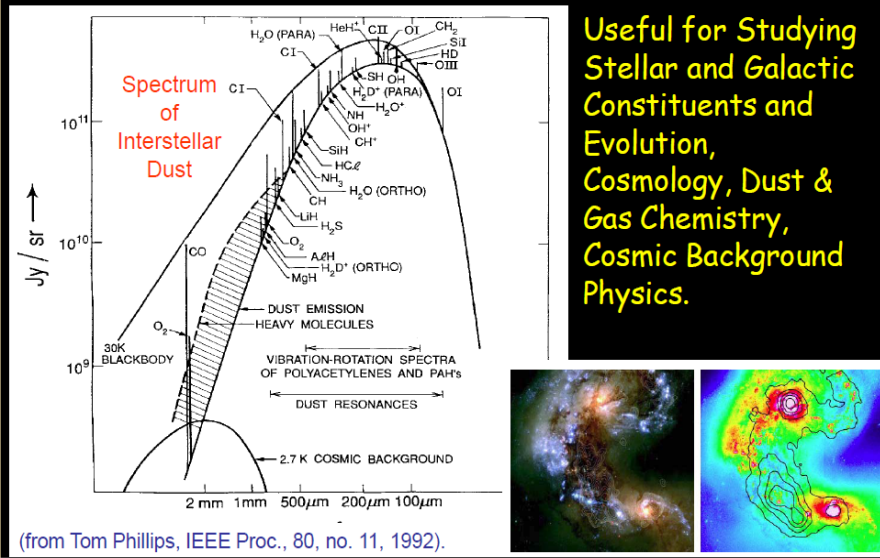

Useful for Studying Stellar and Galactic Constituents and Evolution, Cosmology, Dust & Gas Chemistry, Cosmic Background Physics.

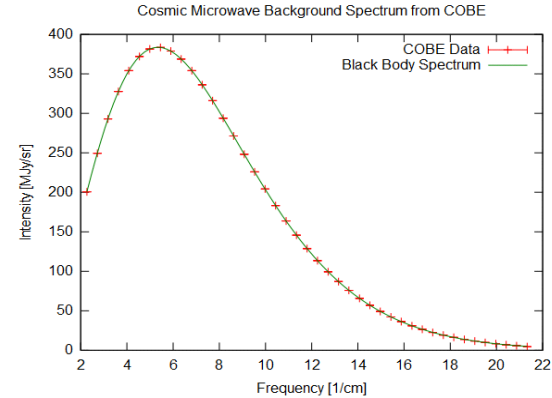
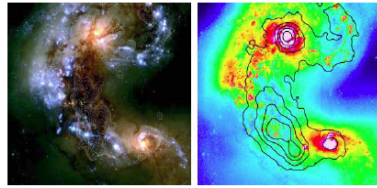

Cosmic Microwave Background was detected by Arno Penzias and Rob Wilson in 1964 by using a Dicke Radiometer with perfectly fitted Planck Blackbody radiation temperature at 2.7K



Dicke Radiometer at Crawford Hill of ATT Bell Laboratories

宇宙造成

The Expanding Universe

Universe started from a "Big Bang" !

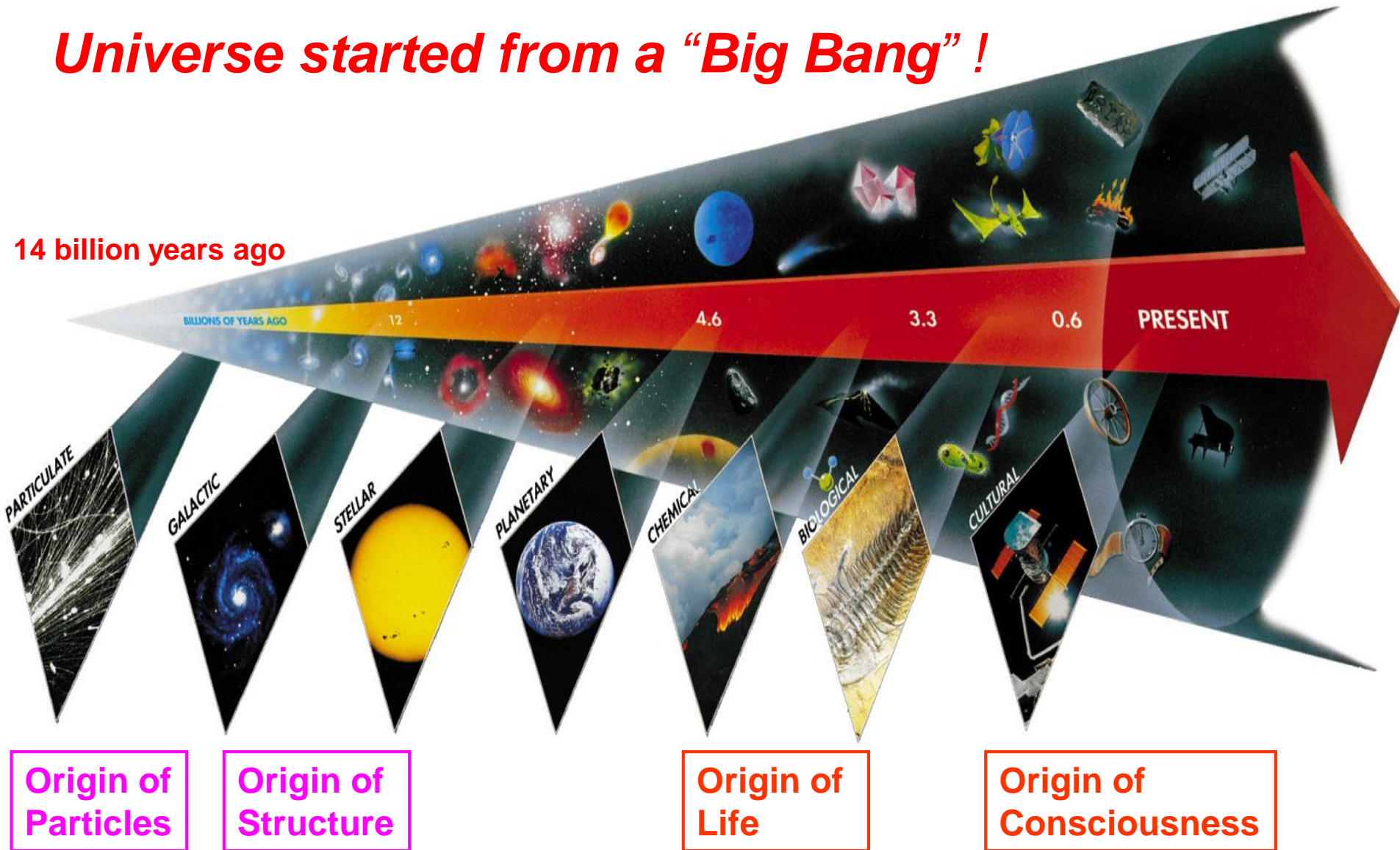

物理學家如何看早期宇宙？

Physicists' View of Early Universe

Fiat lux !!

神說：要有光，就有了光。

And God said:

“Let there be light.”

(創世紀, Genesis 1:3)

Composition of the Universe

宇宙構造

Cosmological Constraints

Ordinary Matter is only 5% of the known universe!

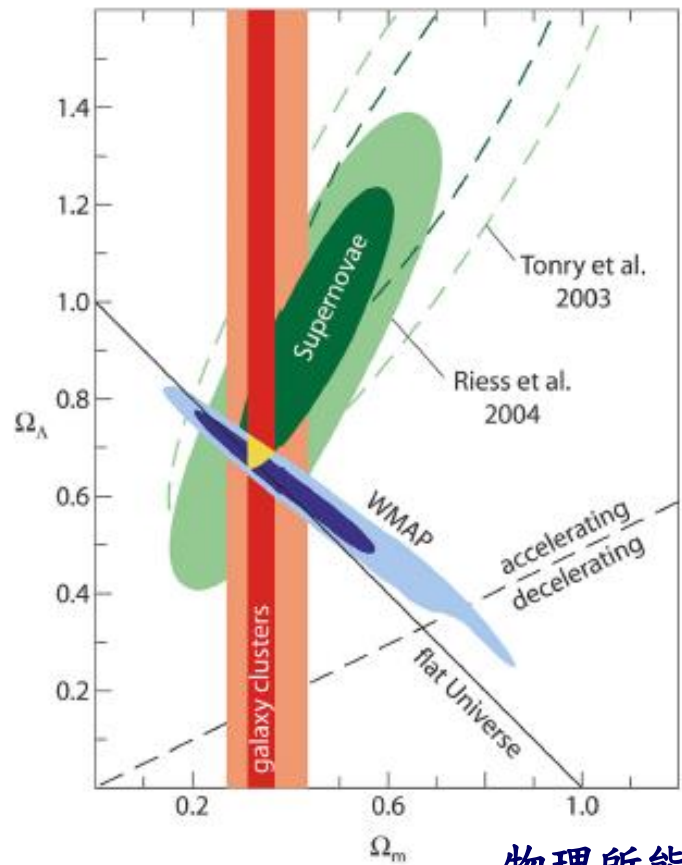

Universe Mass Composition

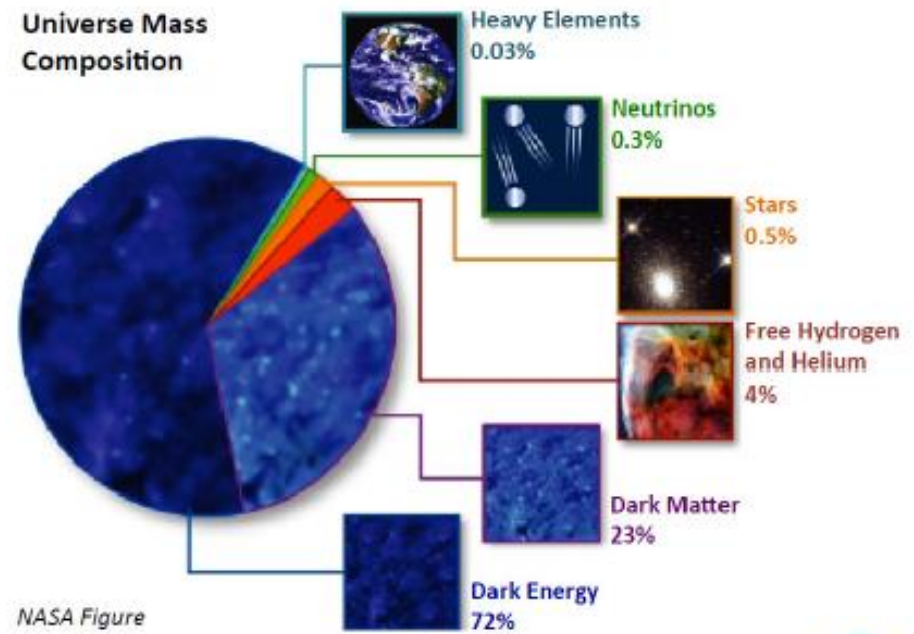

物理所能偵知世界約佔宇宙5%
95%的宇宙是物理可測的限度之外



Evidence for Dark Matter

黑暗物質的證據

Galactic Rotation Curves

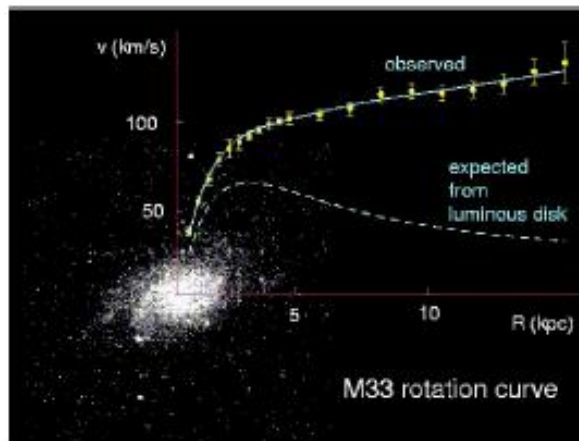

Gravitational Lensing



Cosmic Microwave Background (CMB)

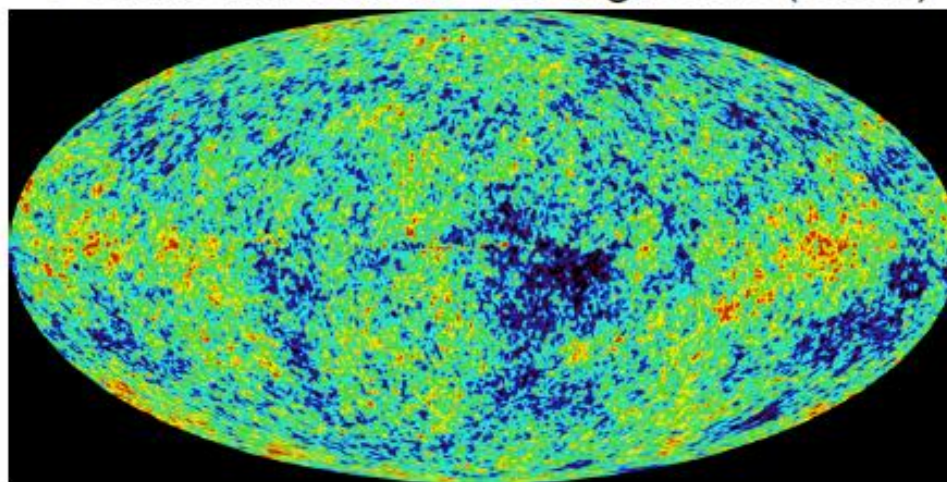

神奇宇宙

The Incredible and Magnificent Universe

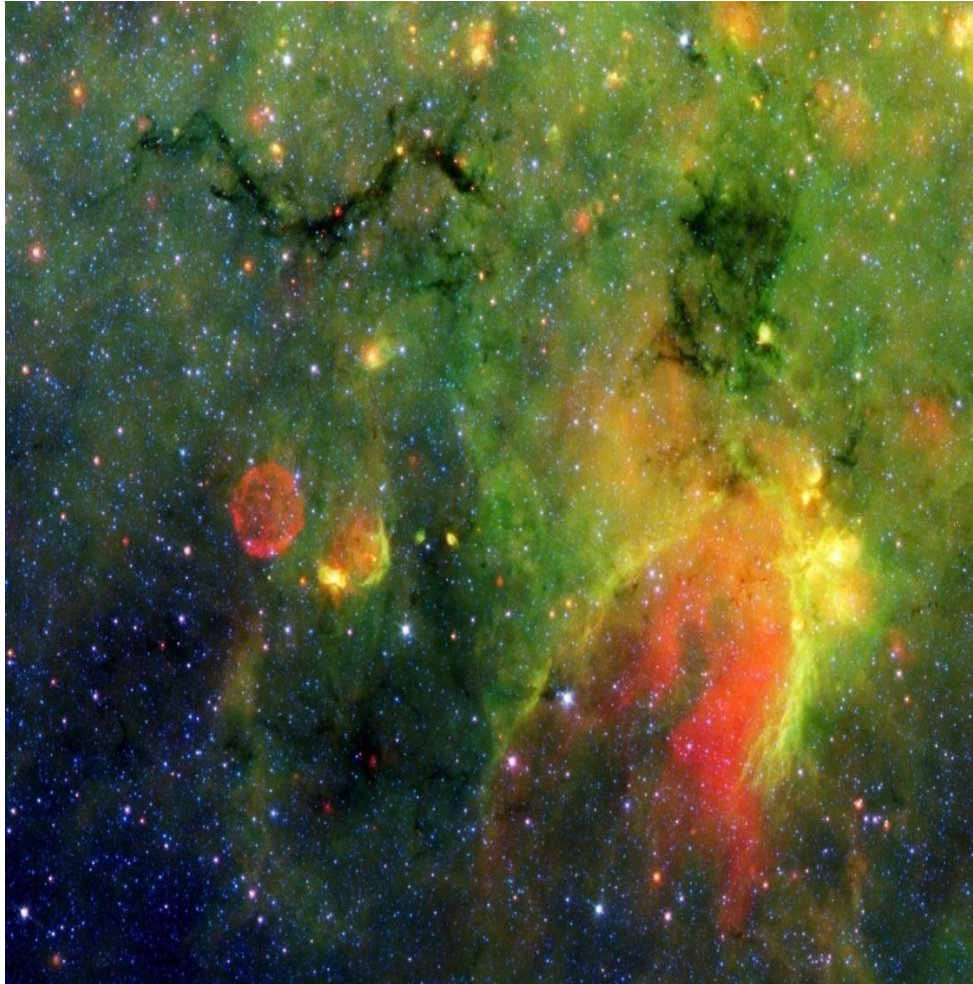

求你開我的眼睛、
使我看你律法中
的奇妙。(詩篇 119:18)
Open thou mine eyes, that
I may behold wondrous
things out of thy law.
(Psalm 119:18)

三句不離本行

工程系統三要件

- **傳感器 (Input Sensors, Analog-to-Digital Converter)**
- **控制器 (Parameters Estimation/Memories/ Decision Making /Cautious Control)**
- **執行器 (Output Actuators, Digital-to-Analog Converter)**

視覺傳感 (Human Sight)

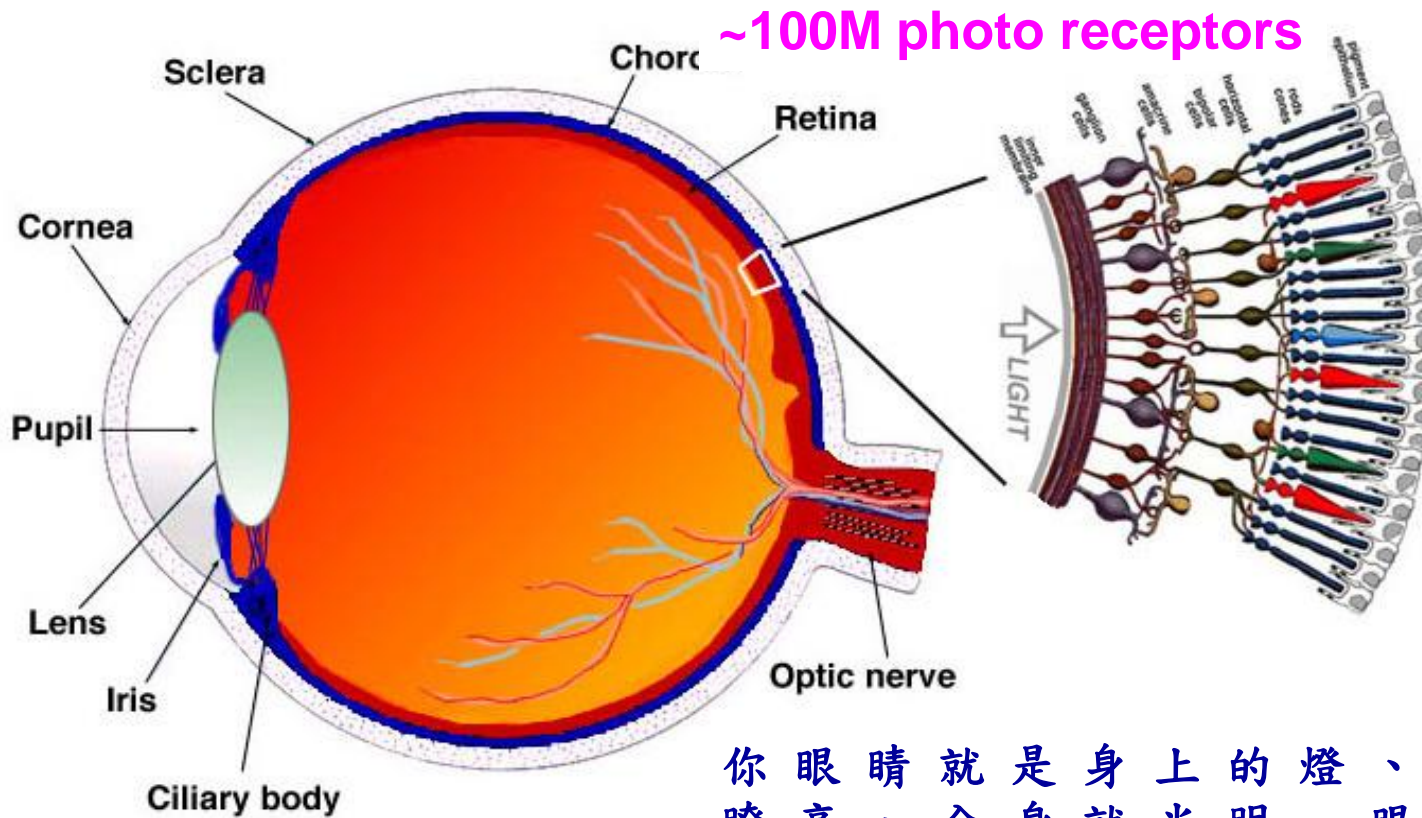

你眼睛就是身上的燈、你的眼睛若
瞭亮、全身就光明。眼睛若昏花、
全身就黑暗。(路加福音 11:34)

The light of the body is the eye: when your eye is true, all your body is full of light; but when it is evil, your body is dark. (Luke 11:34)

電磁波頻譜 *EM Wave Spectrum*

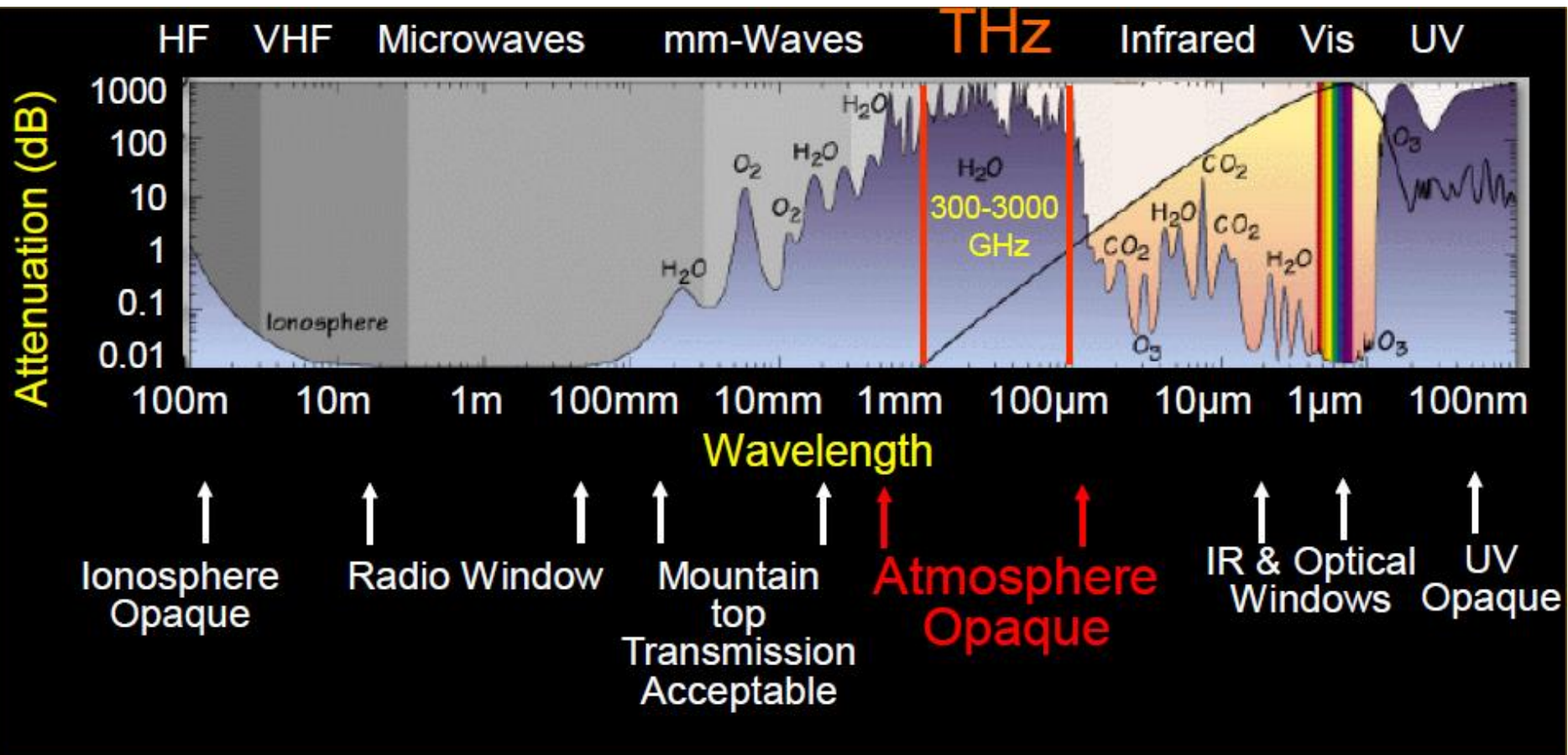

It is a living miracle that visible light (4000-700A) coincides exactly to the peak of Ozone (O₃) absorption

(Courtesy JPL)

Goal of Retinal Prosthesis at UCLA/USC

■ **Model 1 (Argus 1 - 16 pixels; mobility testing)**

- Available as prototype but test device only
- Patients NLP or bare LP due to Retinitis Pigmentosa
- Ability of character reading, object recognition, and direction detection

■ **Model 2 (Argus 2 - 60 pixels; mobility aid)**

- Received CE Mark and USA FDA Approval
- Implantable chips designed by UCLA team



■ **Model 4 (1000+ pixels; reading/face recognition)**

- Expect prototype device (2014)
- Implantable chips designed by UCLA team
- Patients with 20/200 or worse vision
- Patients with retinal blindness (macular degeneration)

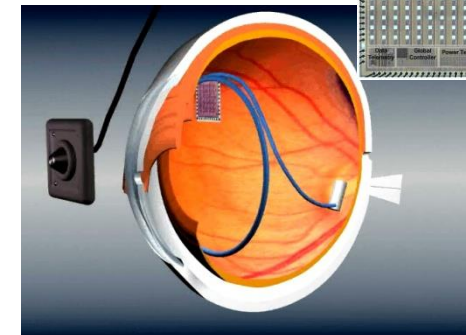
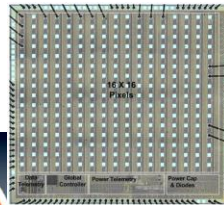
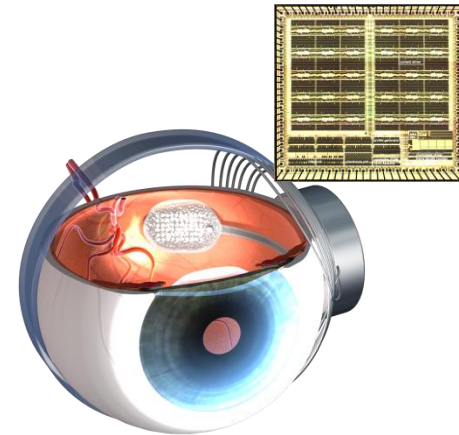
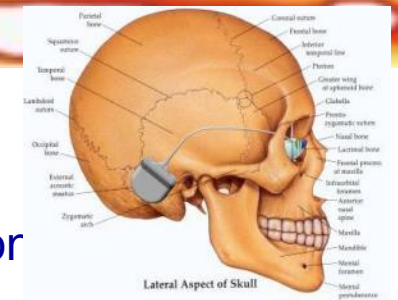

Courtesy Prof. Wen-Tai Liu, UCLA

傳感, 控制, 執行

Sensory Input and Decision Making in Brain

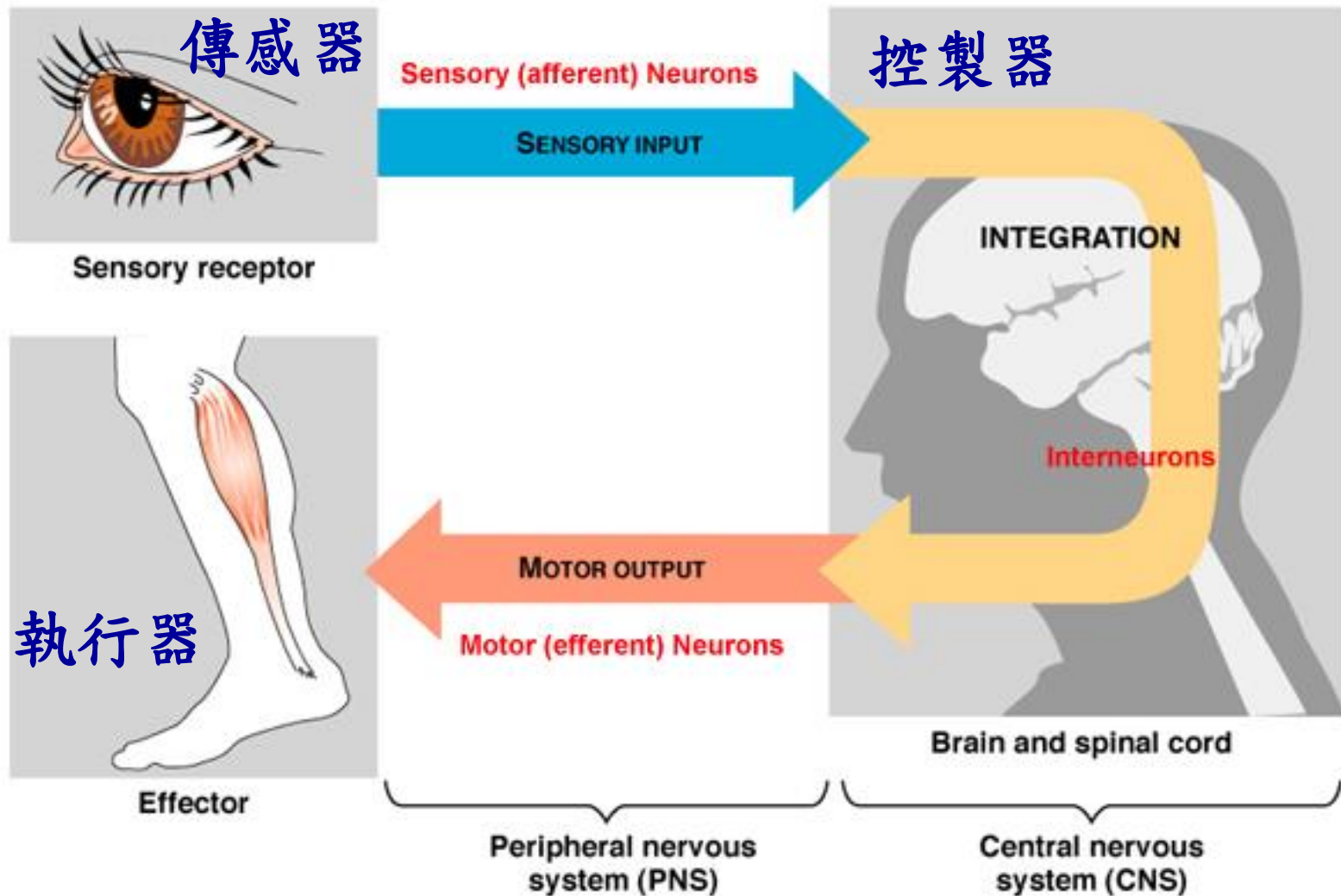

System Block Diagram

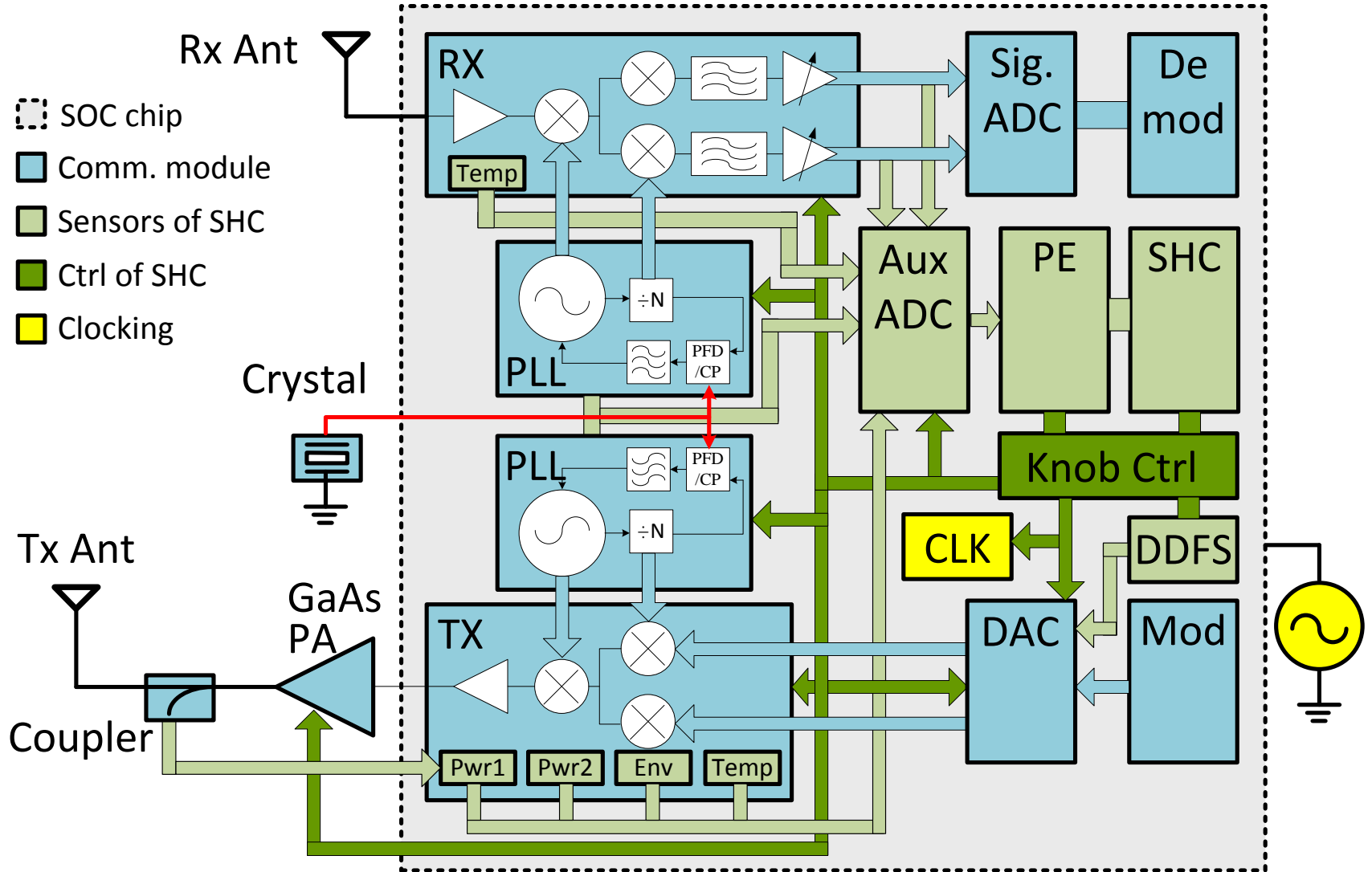

SOC Sensors Distribution

**On-chip PA
Power Sensor**

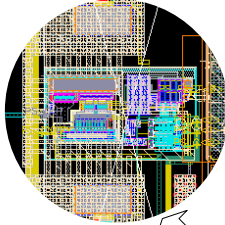

**Rx Temp.
Sensor**

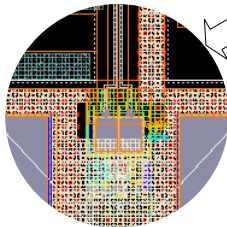
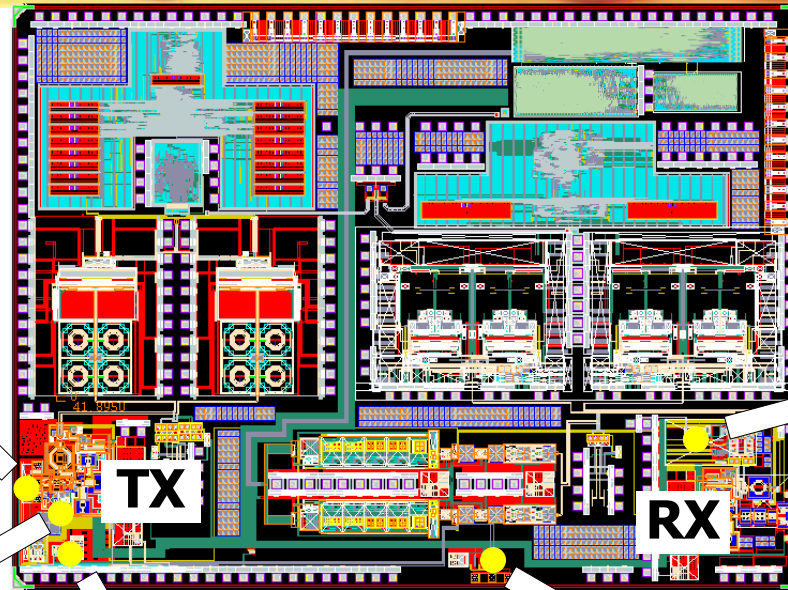
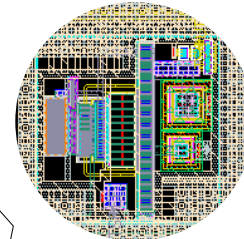

**On-chip PA
Envelop Detector**

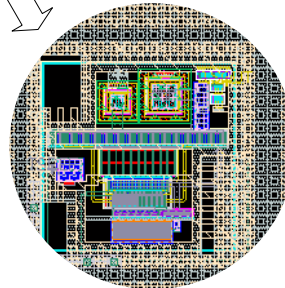

**Tx Temp.
Sensor**

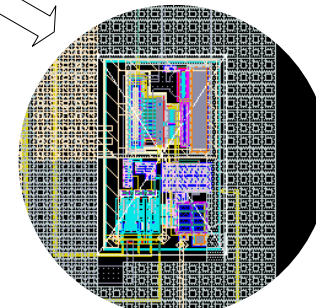

**Off-chip PA
Power Sensor**

受造奇妙可畏！ How could it be accomplished!

“我的肺腑是你所造的。我在母腹中你已覆庇我。我要稱謝你因我受造奇妙可畏。” 詩篇一百三十九篇十三至十四節

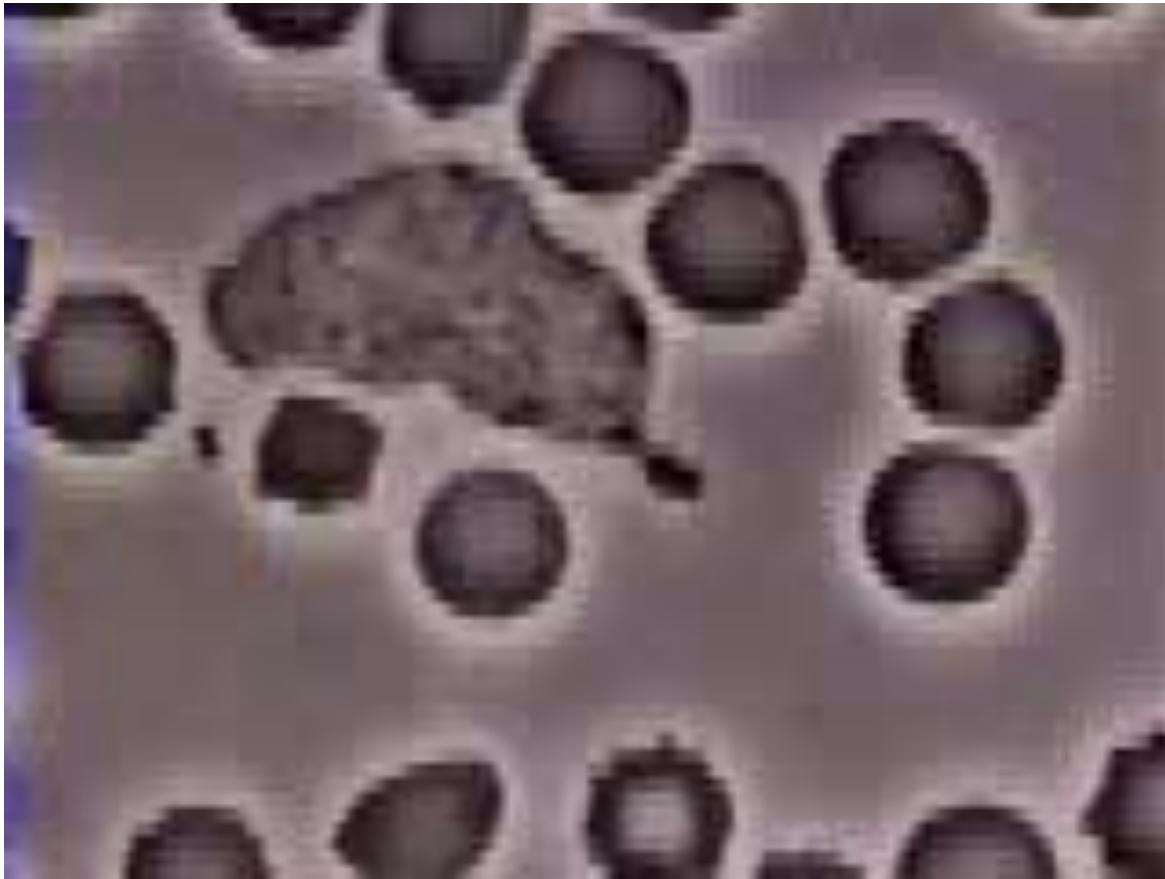

For you created my
inmost being; you
knit me together in
my mother's womb.

I praise you
because I am
fearfully and
wonderfully made;
your works are
wonderful, I know
that full well.
(Psalm 139: 13-14)

如何從遠處辨識一個人？

How can I recognize a person so far away?



- Genetically encoded? 基因認知？
- Learning and memory? 記憶和學習？

The Cerebral Cortex 大腦皮層

Conscious

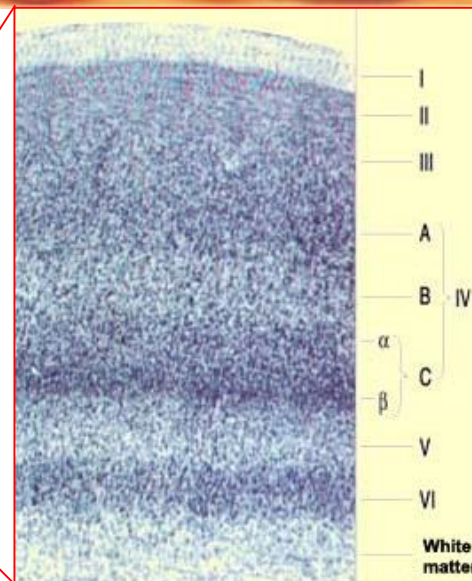
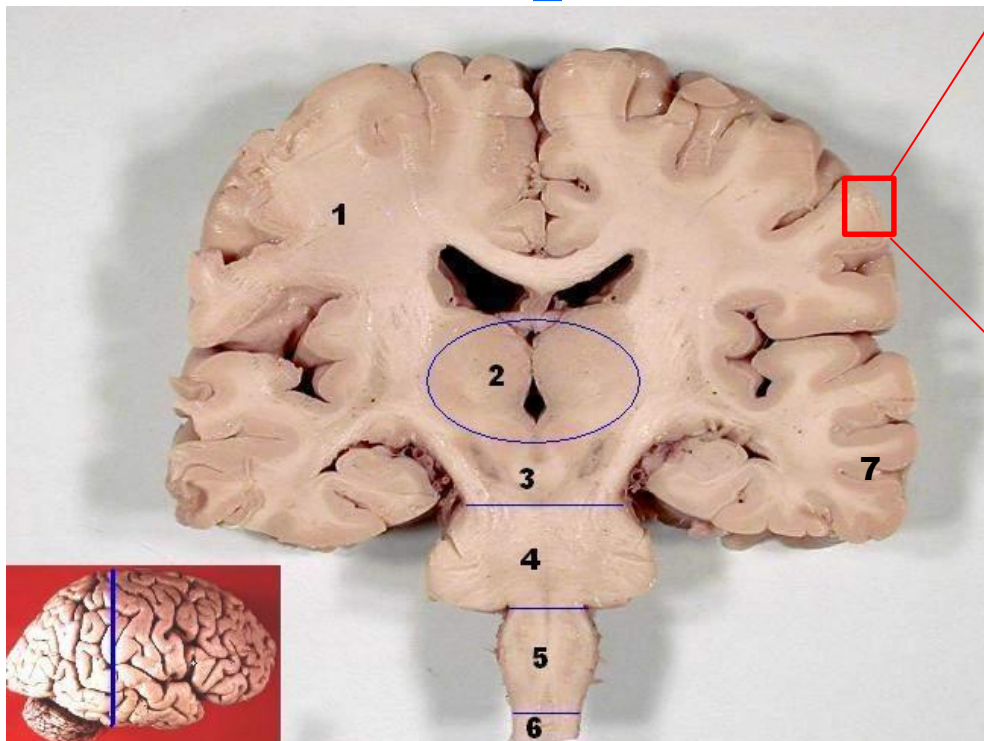

Unconscious

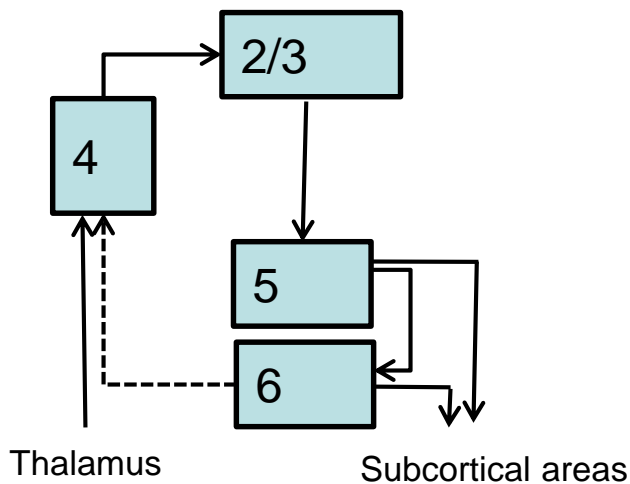

神經 Neurons

Each Neuron has ~1,000 connections ($10^{11} \times 1000 = 10^{14}$)

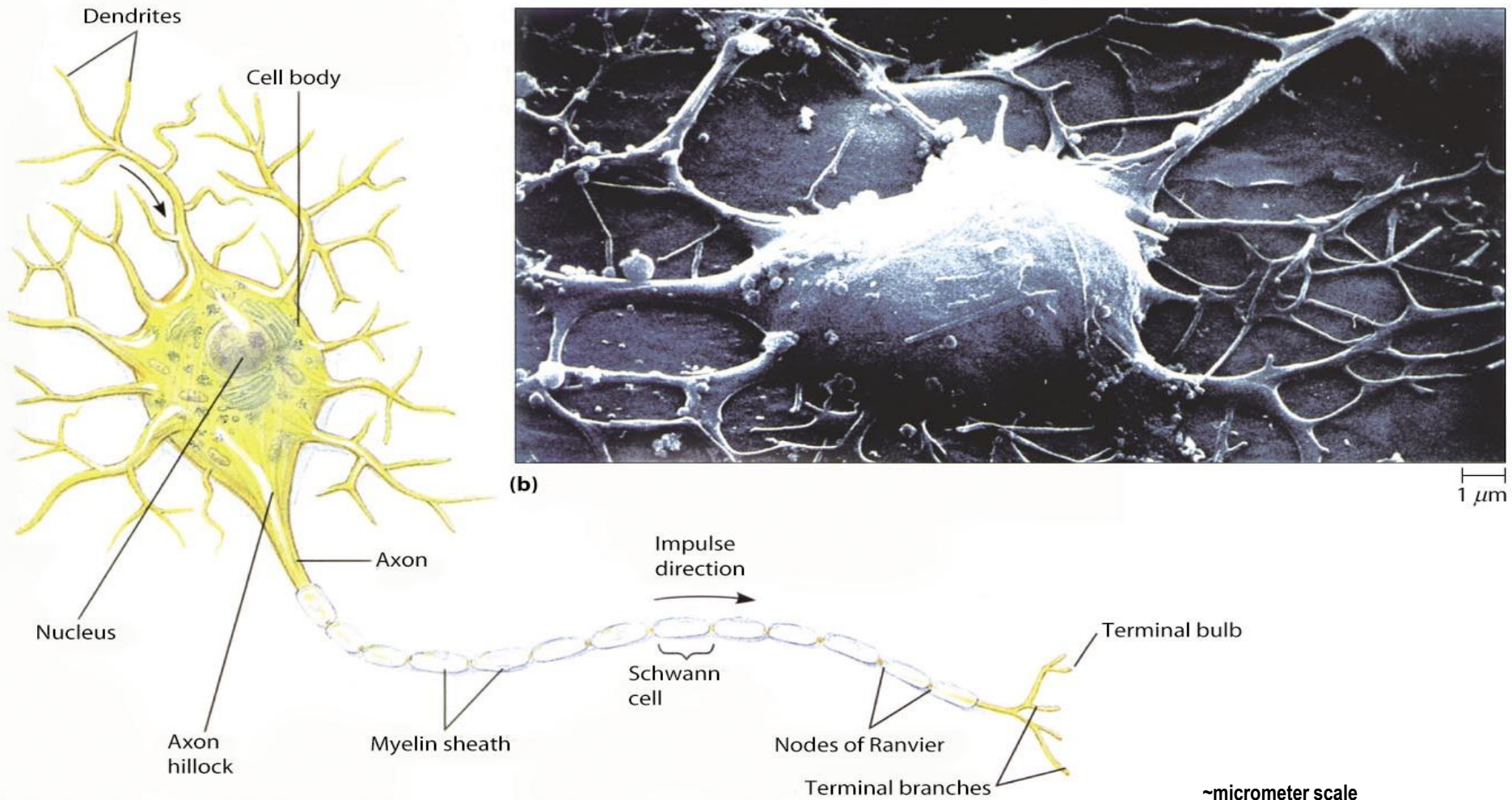

Brain

大腦

Universe

宇宙

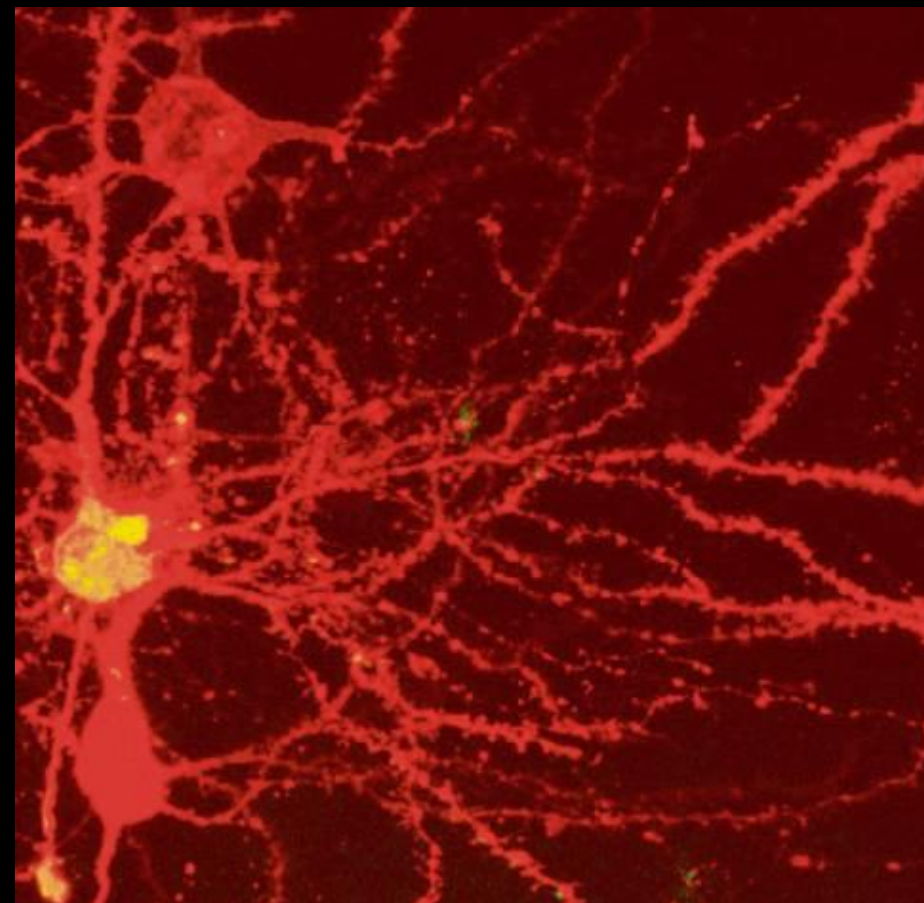

100 Billions Neurons

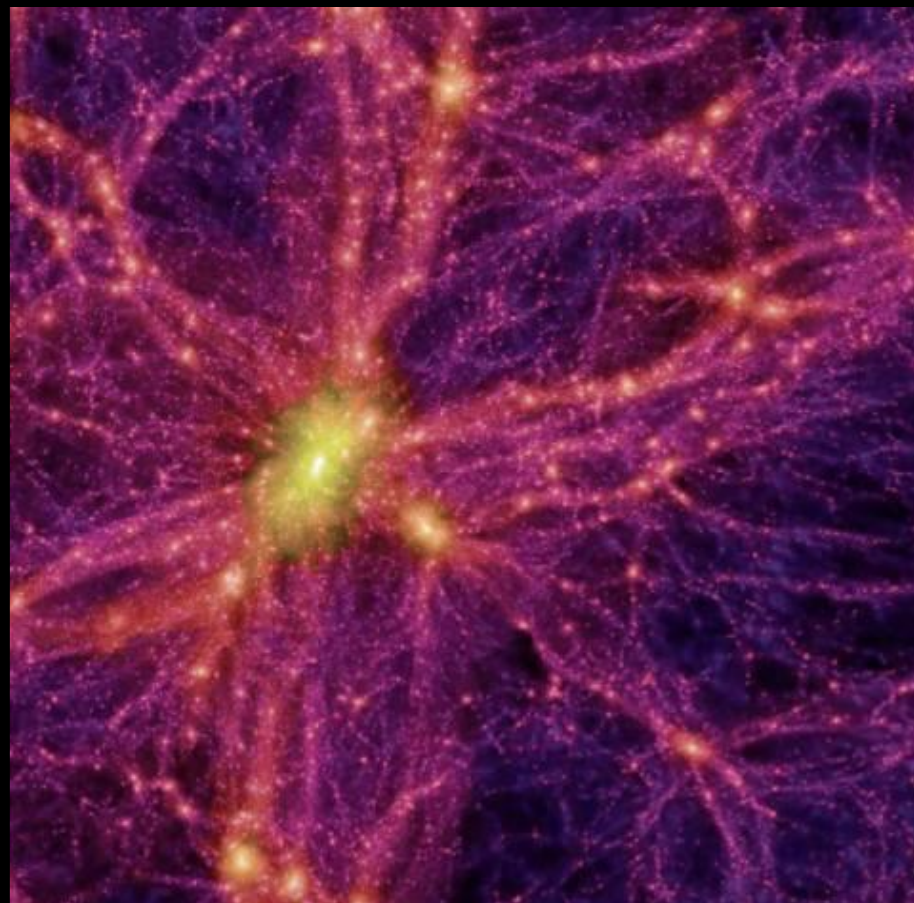

100 Billions Galaxies

老鼠皮質電路發展過程

Assembly of rat's cortical circuits during development

How/when do neurons establish networks? → *Symmetry Breaking*

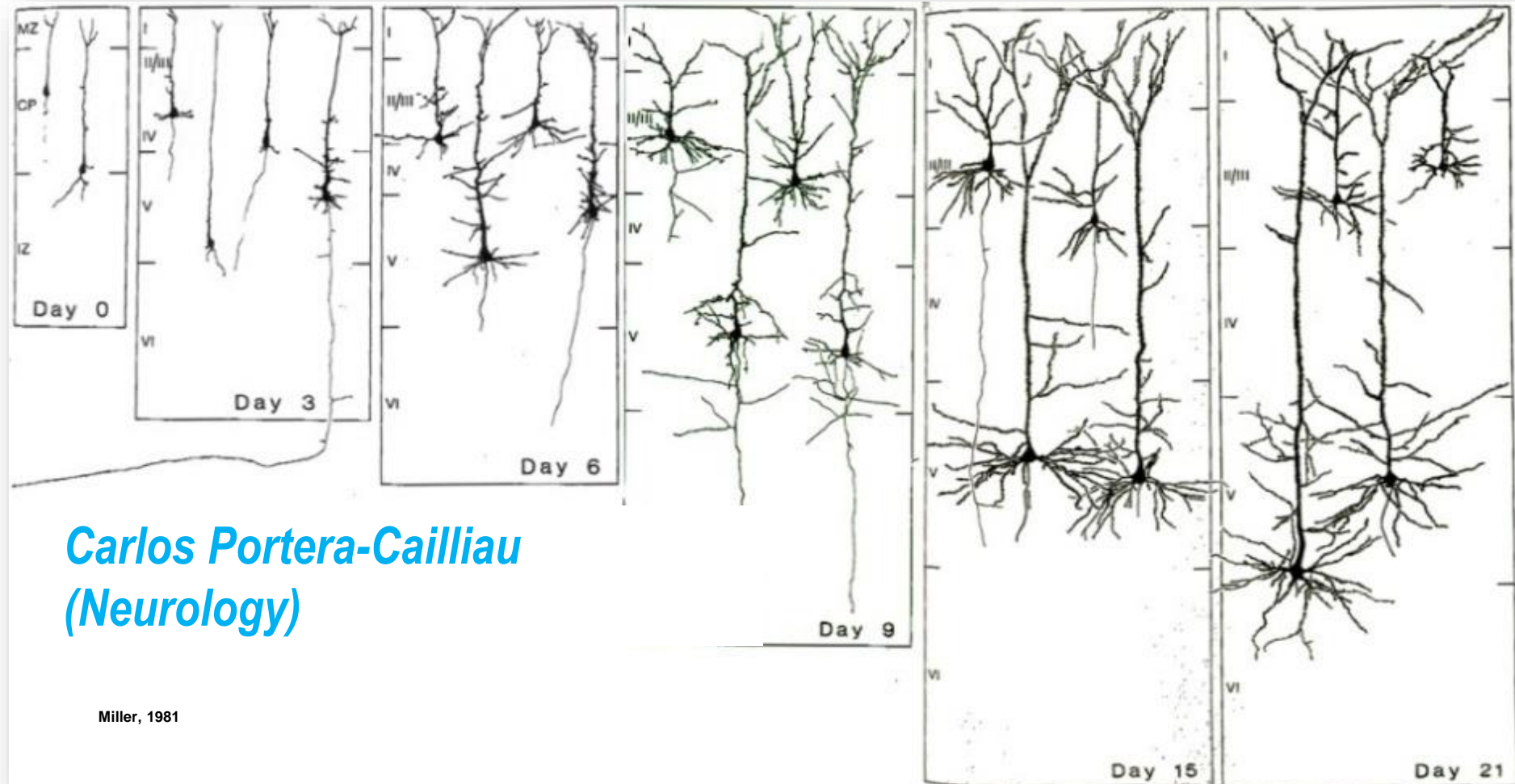

Carlos Portera-Cailliau
(Neurology)

電腦對人腦 (Computer versus Brain)

	Computer (Watson)	Human Brain
Key Unit	Transistor	Neuron
No. of units	$\sim 10^9$ ($\sim 10^{12}$)	$\sim 10^{11}$
Connection	Copper Wire	Axon + Dendrite
No. of Connections	$\sim 10^{10}$ ($\sim 10^{13}$)	$\sim 10^{14}$
Signal Carrier	Electrons	Ions (Na+, Ca+, K+)
Clock Speed	~ 1 GHz	~ 1 kHz
Method	Sequential	Parallel Processing



Human Brain vs. State-of-the-Art Chip



~20W, "3D"
~100B Neural Cells
(~1T Transistors)

VS.

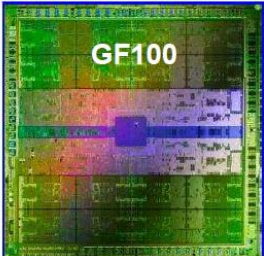

~200W, "2D"
~3B Logic Transistors

We are **power constrained** and must learn from nature

- Make density our friend at less power per transistor – e.g. parallelism → Density is performance

Collaborate to Innovate™

Who Build Human Operation System? Hardware & Software Co-Design? Where are software codes stored?

加碼的基因結構

Coded DNA

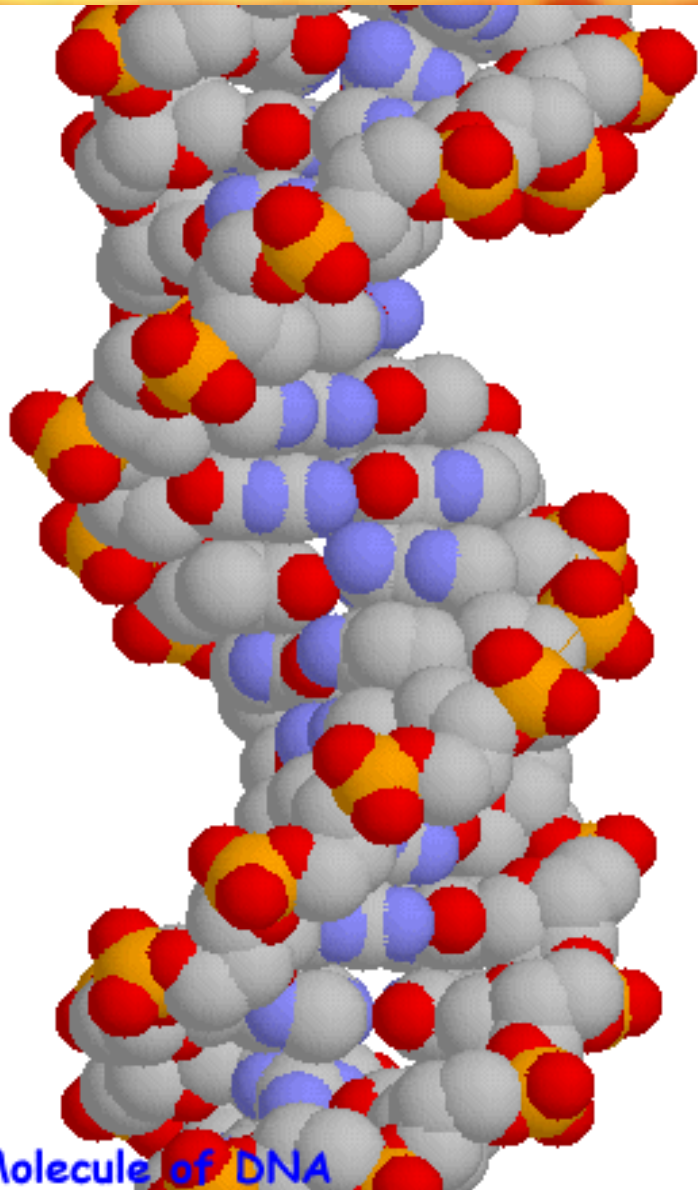

©Rothamsted Experimental Station, 1997, 1998

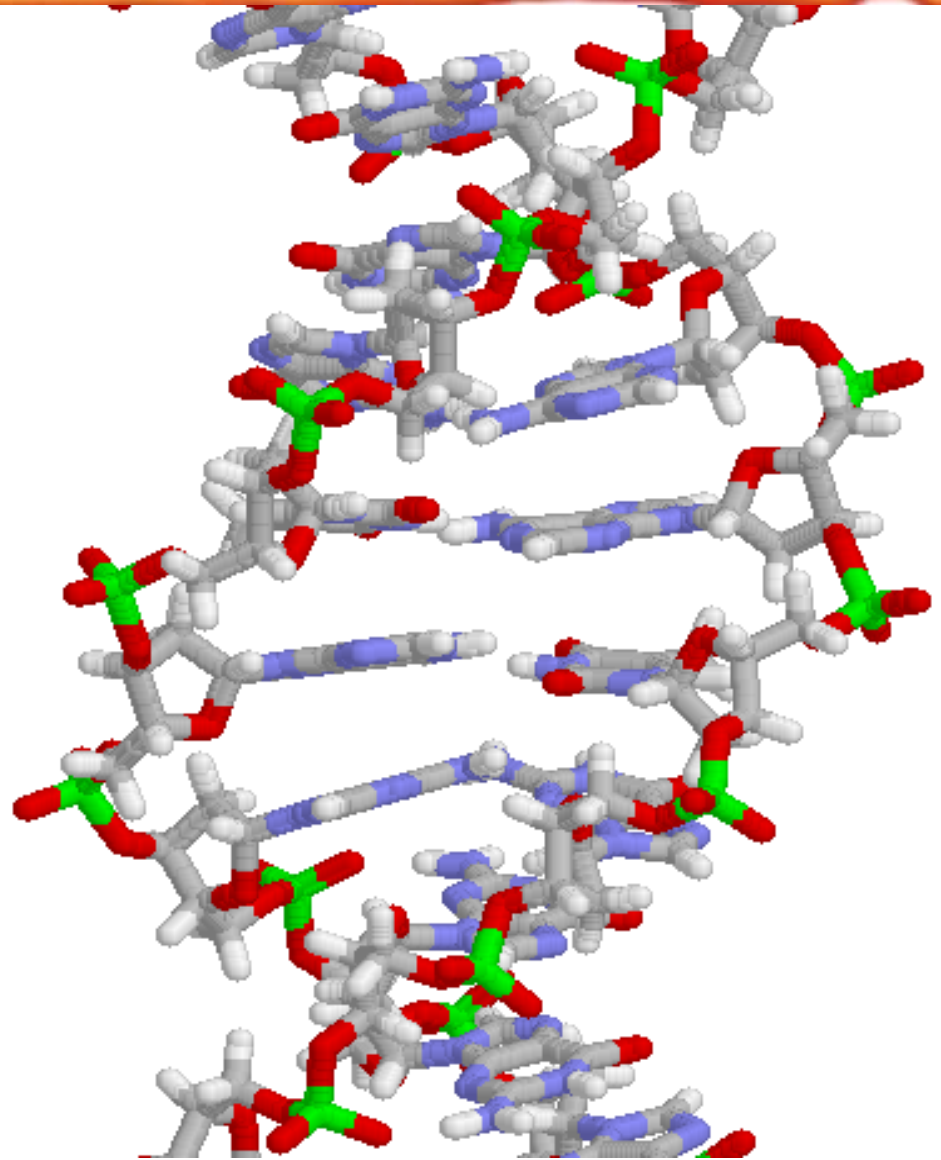

Molecule of DNA

Human Migration from Africa from One Mother (Eve, based on Mitochondria identification)

人類從非洲同一母親遷移的歷史背景



Eve and Adam Originated?

Shorter than 150,000 years history.

信仰不同於宗教 Faith Different from Religion

信就是所望之事的實底、是未見之事的確據。
(希伯來書 11:1)

Now faith is the substance of things hoped for, the evidence of things not seen. (Hebrews 11:1)

那一樣事不靠信仰就能接受？

- $1+1=2$
- 牛頓萬有引力定律: **Newton's universal gravitation law: $G[M_1 \times M_2]/r^2$**
- 光的羣速度是常數: **Group velocity of light: 300,000Km/sec**
- 光是波又是粒子: **Light is both particle and wave**
- 光能在真空裏傳播: **Light can propagate in vacuum**
- 熱力學第二定律: **Second law of thermodynamics: Entropy will always increase from one equilibrium state to another equilibrium state** 热力学系统从一个平衡态到另一平衡态的过程中，其熵(混亂的程度)永不减少
- 宇稱不守恒: **Parity is not conserved in weak interactions**
- 進化論: **Evolution hypothesis.....**

自從造天地以來，神的永能和神性是明明可知的。雖是眼不能見，但藉著所造之物，就可以曉得，叫人無可推諉。(羅馬書 1:20)

For the invisible things of him since the creation of the world are clearly seen, being perceived through the things that are made, even his everlasting power and divinity; that they may be without excuse. (Romans 1:20)

自然所設計? 誰是自然? Nature designed it?

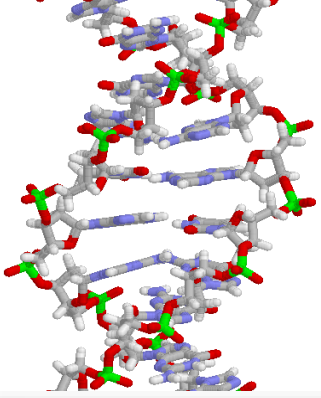

自然?
Nature?

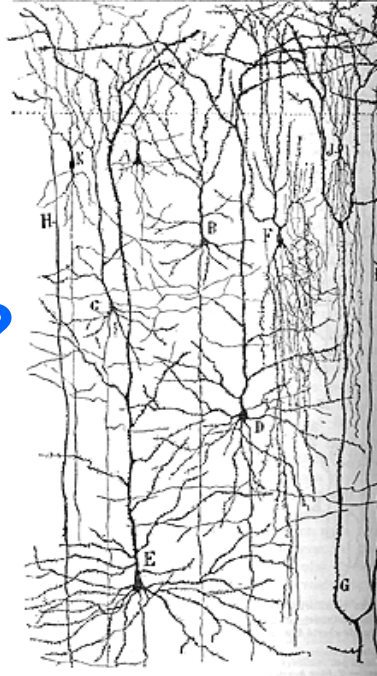

自然?
Nurture?

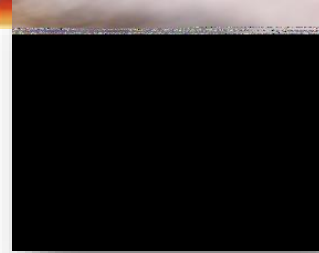
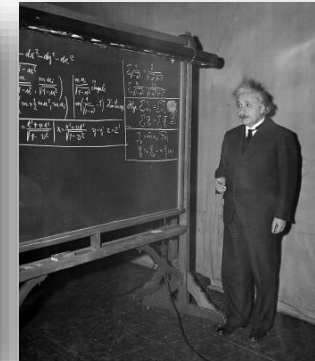
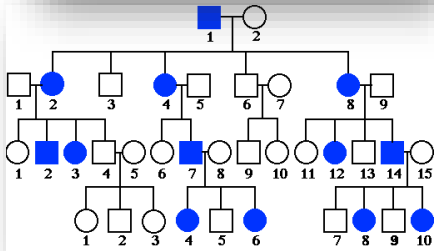

神名自然(耶和華、雅威或道)

神回答摩西：“我是自有永有者”（自然）

（出埃及記 3:14）

God said to Moses, “I am who I am.” Exodus 3:14

示字部

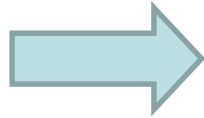

The left hand side of Chinese character “God” means **revelation**.

神

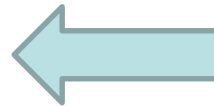

申

The right hand side of Chinese character “GoD” means **statement**.

太初有道、道與 神同在、道就是 神。這道太初與 神同在。萬物是藉著他造的。凡被造的、沒有一樣不是藉著他造的。生命在他裏頭。這生命就是人的光。（約翰福音 1:1-4）

In the beginning was the Word, and the Word was with God, and the Word was God. He was with God in the beginning. Through him all things were made; without him nothing was made that has been made. In him was life, and that life was the light of man. (John 1:1-4)

神愛世人

神愛世人、甚至將他的獨生、
子賜給他們、叫一切信他的、
不至滅亡、反得永生。因為
神差他的兒子降世、不是要
定世人的罪、乃是要叫人
因他得救。約翰 3:16

For God so loved the world, that he gave his only begotten Son, that whosoever believeth in him should not perish, but have everlasting life.

誰是耶穌？ (I)

- 是神的兒子道成肉身

道成了肉身，住在我們中間，充充滿滿地有恩典，有真理。我們也見過他的榮光，正是父獨生子的榮光。約翰1:14

The word became flesh and made dwelling among us. We have seen his glory, the glory of one and only Son, who came from the Father, full of grace and truth. (John 1:14)

- 能掌管生死(叫死人復活，自己死後三日復活並七次向門徒顯明)

說了這話、就大聲呼叫說、拉撒路出來。那死人就出來了、手腳裹著布、臉上包著手巾。耶穌對他們說、解開、叫他走。約翰:11:33-34

Then he said in a loud voice, Lazarus, come out! And he who was dead came out, with linen bands folded tightly about his hands and feet, and a cloth about his face. Jesus said to them, Make him free and let him go.

天使對婦女說、不要害怕、我知道你們是尋找那釘十字架的耶穌。他不在這裡、照他所說的、已經復活了。你們來看安放主的地方。

And the angel said to the women, Have no fear: for I see that you are searching for Jesus, who was put to death on the cross. He is not here, for he has come to life again, even as he said. Come, see the Lord's resting-place.

誰是耶穌？ (II)

- 為要尋找拯救失喪的人 (路加**19:10**). 為要拯救罪人(提摩太前書**1:15**)
- For the Son of man is come to seek and to save that which was lost.
Luke 19:10
- Christ Jesus came into the world to give salvation to sinners, of whom I am the chief: Timothy 1:15
- 在我們愛祂之前先愛我們. 為赦免我們的罪能與父神和好寧願自己被釘十字架而死
- 人為朋友捨命、人的愛心沒有比這個大的。約翰福音**15:13**
Greater love has no man than this, that a man gives up his life for his friends. John 15:13
- 惟有基督在我們還作罪人的時候為我們死、神的愛就在此向我們顯明了。羅馬書**5:8** But God has made clear his love to us, in that, when we were still sinners, Christ gave his life for us. Romans 5:8)

耶穌是道路, 真理, 生命(Jesus is Way, Truth, Life)

我就是**道路, 真理, 生命**, 若不藉著我, 沒有人能到父那裏去。
(約翰14章6節)

I am the **way** and the **truth** and the **life**. No one comes to the Father except through me. (John 14:6)

我是世界的光, 跟從我的就不在黑暗裏走, 必要得到**生命的光**
(約翰8章12節)

I am the **light of the world**. Whoever follows me will never walk in darkness, but will have the **light of life**. (John 8:12)

復活在我, **生命也在我**. 信我的人雖然死了, 也必復活. 凡活著信我的人, 必永遠不死. (約翰11章25-26節)

I am the **resurrection and the life**. He who believes in me will live, even though he dies; and whoever lives and believes in me will never die. (John 11:25-26)

作神的兒女 Become Children of God

人非有信、就不能得神的喜悅。因為到神面前來的人、必須信有神，且信他賞賜那尋求他的人。希伯來書 11:6

But without faith it is impossible to please him: for he that cometh to God must believe that he is, and that he is a rewarder of them that diligently seek him. Hebrews : 11:6

然而我今日成了何等人、是蒙神的恩纔成的。並且他所賜我的恩、不是徒然的。我比眾使徒格外勞苦。這原不是我、乃是神的恩與我同在。哥林多前書 15:10

But by the grace of God I am what I am: and his grace which was bestowed upon me was not in vain; but I laboured more abundantly than they all: yet not I, but the grace of God which was with me. 1 Corinthians 15:10

如何作神的兒女？

- **Admit** 承認

因為世人都犯了罪、虧缺了 神的榮耀。羅馬3:23

For all have sinned, and come short of the glory of God. Romans 3:23

- **Believe** 相信

就是 神的義、因信耶穌基督、加給一切相信的人、並沒有分別。羅馬 3:22

Even the righteousness of God which is by faith of Jesus Christ unto all and upon all them that believe: for there is no difference. Romans 3:22

- **Confess** 宣告

你若口裡認耶穌為主、心裡信 神叫他從死裡復活、就必得救。羅馬 10:9

That if thou shalt confess with thy mouth the Lord Jesus, and shalt believe in thine heart that God hath raised him from the dead, thou shalt be saved. Romans 10:9